

COMBINED SCIENCE

5129/12

Paper 1 Multiple Choice

October/November 2017

1 hour

Additional Materials: Multiple Choice Answer Sheet
 Soft clean eraser
 Soft pencil (type B or HB is recommended)

* 6 7 4 0 1 6 0 5 4 5 *

READ THESE INSTRUCTIONS FIRST

Write in soft pencil.

Do not use staples, paper clips, glue or correction fluid.

Write your name, Centre number and candidate number on the Answer Sheet in the spaces provided unless this has been done for you.

DO NOT WRITE IN ANY BARCODES.

There are **forty** questions on this paper. Answer **all** questions. For each question there are four possible answers **A, B, C** and **D**.

Choose the **one** you consider correct and record your choice in **soft pencil** on the separate Answer Sheet.

Read the instructions on the Answer Sheet very carefully.

Each correct answer will score one mark. A mark will not be deducted for a wrong answer.

Any rough working should be done in this booklet.

A copy of the Periodic Table is printed on page 16.

Electronic calculators may be used.

This document consists of **14** printed pages and **2** blank pages.

1 What is the function of the cell membrane?

- A It controls the activities of the cell.
- B It controls the passage of substances into and out of the cell.
- C It is where respiration occurs.
- D It is where the cell's chemical reactions occur.

2 The diagram represents how some red blood cells change when they are placed in solution X.

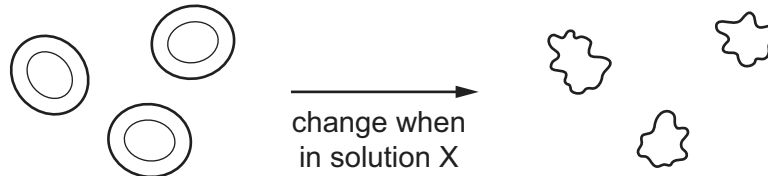

What describes the water concentration in solution X and in which direction does water move?

	water concentration in solution X	direction of water movement
A	higher than in cells	into the cells
B	higher than in cells	out of the cells
C	lower than in cells	into the cells
D	lower than in cells	out of the cells

3 Why does the enzyme amylase **not** work in the stomach?

- A Amylase only works in the mouth.
- B The stomach is too acidic.
- C The stomach is too alkaline.
- D The stomach is too hot.

4 The diagram shows a cross-section of a leaf.

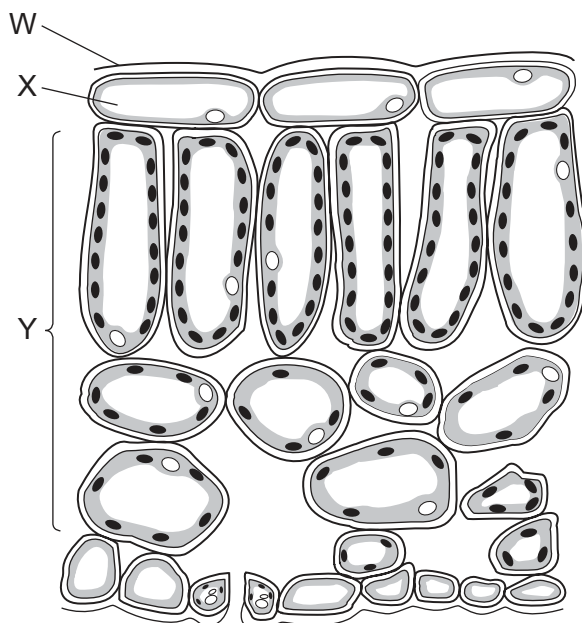

Which row in the table correctly identifies structures W, X and Y?

	W	X	Y
A	cuticle	epidermis	mesophyll
B	cuticle	epidermis	vascular bundle
C	epidermis	cuticle	mesophyll
D	epidermis	cuticle	vascular bundle

5 When a child sucks a sweet it may stay in their mouth for some time.

How does this contribute to tooth decay?

- A** The sugar in the sweet stops bacteria from growing.
- B** The teeth are damaged by acid being produced in the mouth.
- C** The teeth are damaged by alkali being produced in the mouth.
- D** The teeth are damaged by artificial flavourings in the sweet.

6 A farmer has a crop growing in his field. The crop is starting to wilt.

Which weather conditions are most likely to stop the crops from wilting?

- A** less rain and less wind
- B** less rain and more wind
- C** more rain and less wind
- D** more rain and more wind

7 What is the function of the platelets in the blood?

- A antibody formation
- B blood clotting
- C oxygen transport
- D phagocytosis

8 The diagram shows one alveolus and its associated capillary.

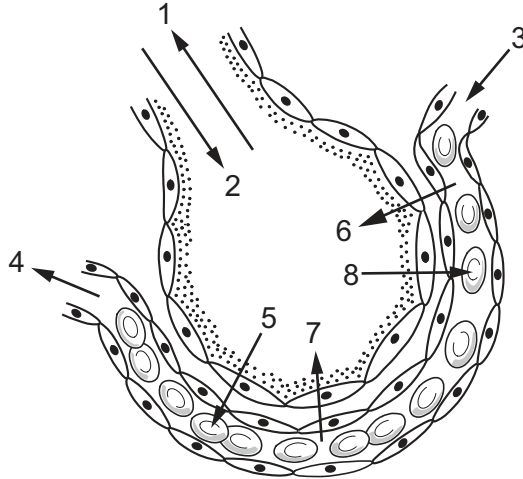

Which arrows correctly show the direction that gases move across the surface of the alveolus?

	oxygen	carbon dioxide
A	1 and 5	4 and 8
B	2 and 7	3 and 6
C	4 and 6	2 and 3
D	5 and 8	6 and 7

9 The table shows the direction of flow of two substances that pass between the capillaries and tissue in a part of the body.

substance	direction of flow
amino acids	out of capillaries into tissue
urea	into capillaries from the tissue

In which part of the body are these capillaries?

- A colon
- B kidney
- C liver
- D villi

10 What happens to a hormone once it has acted on its target organ?

- A It is destroyed by the large intestine.
- B It is destroyed by the liver.
- C It is destroyed by the small intestine.
- D It is destroyed by the stomach.

11 What is alcohol?

- A a depressant
- B a hormone
- C an antibody
- D an enzyme

12 In the diagram, arrows represent the movement of carbon compounds in the carbon cycle.

The circles represent the locations of carbon compounds in animals, decomposers, plants and in the air.

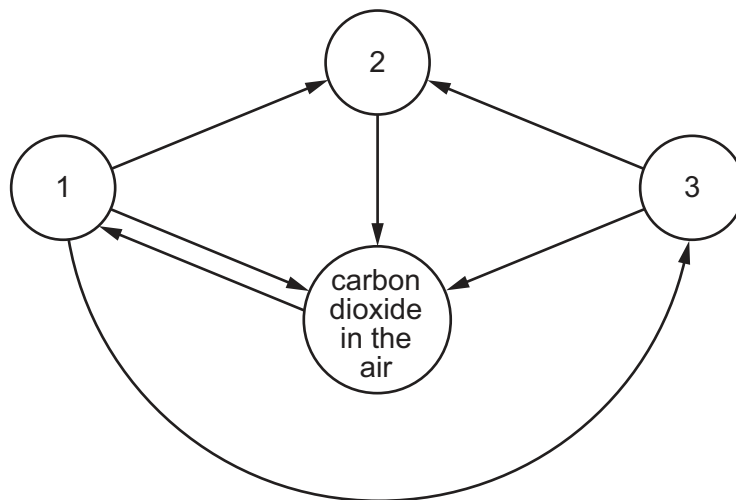

Which location of carbon compounds is represented by each circle?

	1	2	3
A	animals	plants	decomposers
B	decomposers	animals	plants
C	plants	animals	decomposers
D	plants	decomposers	animals

13 A student investigates the effect of temperature on the germination of seeds in petri dishes.

Each batch of seeds is grown at a different temperature.

Which environmental conditions must be kept constant so that the results can be compared?

- A volume of water, carbon dioxide and oxygen concentrations
- B volume of water and carbon dioxide concentration only
- C volume of water and oxygen concentration only
- D volume of water only

14 Water is added to a mixture of sodium chloride and sand.

Which method is used to separate the sand from the mixture?

- A evaporation
- B filtration
- C fractional distillation
- D paper chromatography

15 The arrangement of particles during four changes of state are shown.

In which change of state does the kinetic energy of the particles decrease?

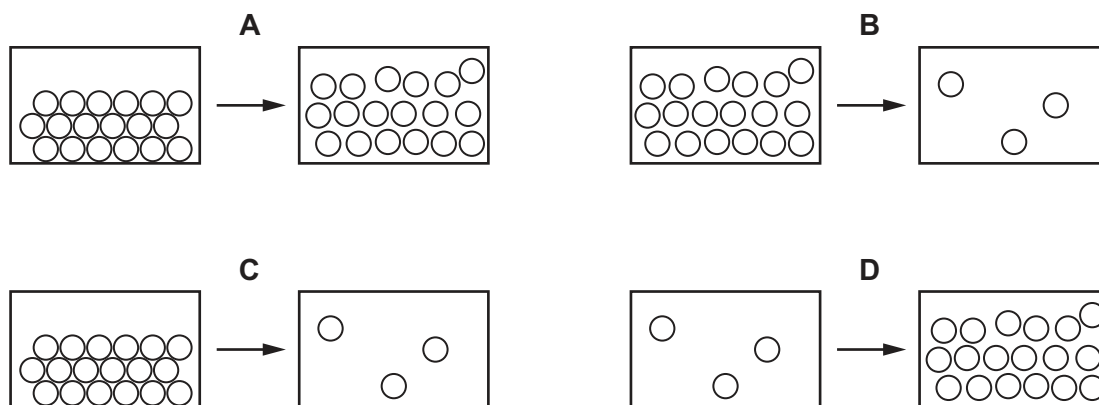

16 How many electrons are in the outer shell of an atom of $^{11}_5\text{B}$?

- A 3
- B 5
- C 6
- D 11

17 The electronic structures of four elements are shown.

Which element forms an ion with a charge of 2-?

	electronic structure
A	2
B	2.8
C	2.8.2
D	2.8.6

18 Elements P and Q combine to form the gas PQ₂.

What are P and Q?

	P	Q
A	calcium	chlorine
B	carbon	hydrogen
C	carbon	oxygen
D	hydrogen	oxygen

19 Iron is extracted from iron oxide in the blast furnace.

The equation for the process is shown.

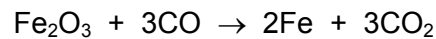

What is the mass of iron that is extracted from 16 g of iron oxide?

- A** 4.8g **B** 5.6g **C** 9.6g **D** 11.2g

20 What is the colour of Universal Indicator in a neutral solution?

- A** blue
B green
C orange
D red

21 Chlorine, bromine and iodine are elements in Group VII of the Periodic Table.

Which statement about these elements is correct?

- A They are gases at room temperature.
- B They are colourless.
- C They are diatomic.
- D They are metals.

22 Which row describes the properties of a metal?

	conducts electricity when solid	malleable
A	no	no
B	no	yes
C	yes	no
D	yes	yes

23 A mixture of ethene, oxygen and sulfur dioxide is passed through the apparatus as shown.

Only one of the gases is collected.

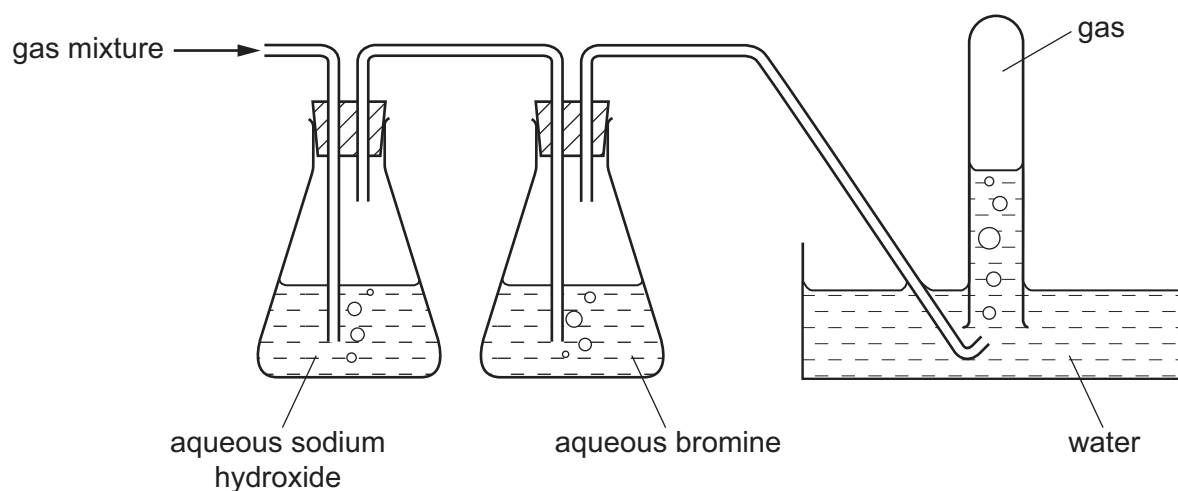

What is a property of the gas collected?

- A It burns with a yellow flame.
- B It relights a glowing splint.
- C It turns limewater cloudy.
- D It turns Universal Indicator red.

24 Which statement about hydrogen is **not** correct?

- A Hydrogen is used as a rocket fuel.
- B Hydrogen reacts with ethane to produce ethene.
- C Sodium reacts with water to produce hydrogen.
- D Water is formed when a lighted splint is placed in a gas jar of hydrogen.

25 The diagrams show the structures of four organic molecules.

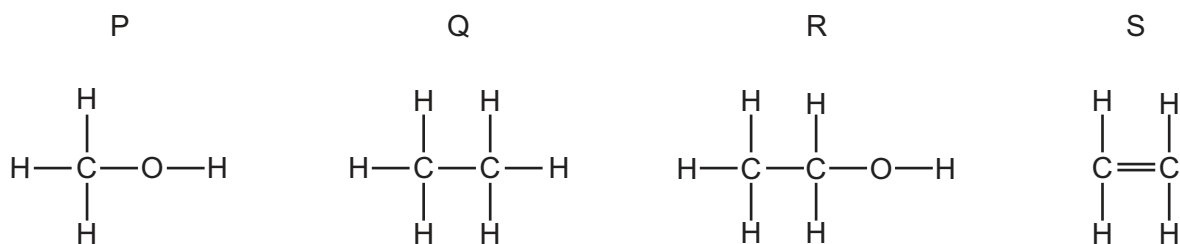

Which two are members of the same homologous series?

- A P and R
 - B P and S
 - C Q and R
 - D R and S
- 26 Ethane gas is heated to produce hydrogen gas and another gas Y which decolourises aqueous bromine.

What is the structural formula of Y?

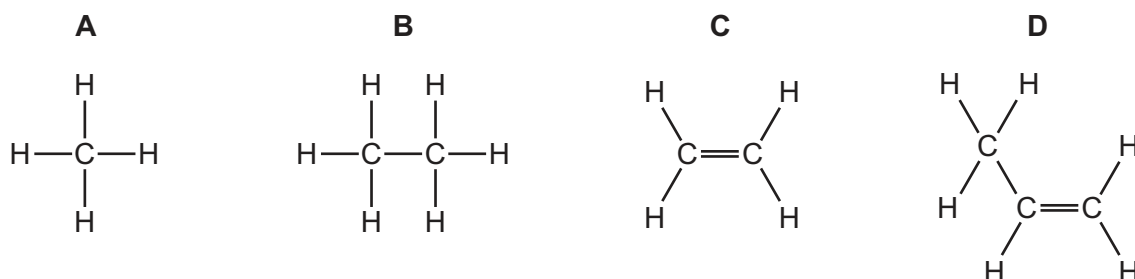

27 An organic chemical is used as a solvent and as a fuel and is a constituent of wine.

What is the chemical?

- A ethanol
- B ethene
- C paraffin
- D propane

- 28 A student drops a coin into a measuring cylinder containing water. He uses the increase in the reading to find the volume of the coin.

A number of instructions help to improve the accuracy of the result.

Which instruction will **not** help to improve the accuracy?

- A Avoid splashing when adding the coin.
 B Make sure the measuring cylinder is on a horizontal surface.
 C Make sure your eye is level with the liquid surface when taking the reading.
 D Use a measuring cylinder with the largest possible volume.
- 29 Which expression can be used to correctly calculate force?
- A mass = force / acceleration
 B mass = force \times acceleration
 C power = force \times time
 D work = force / distance
- 30 50 cm^3 of a liquid has a mass of 40 g.

What is the density of the liquid?

- A 0.80 g/cm^3 B 1.25 g/cm^3 C 10 g/cm^3 D 90 g/cm^3

- 31 Alan and Sarah are sitting on a seesaw. Alan is 1.5m from the pivot and the seesaw is in equilibrium.

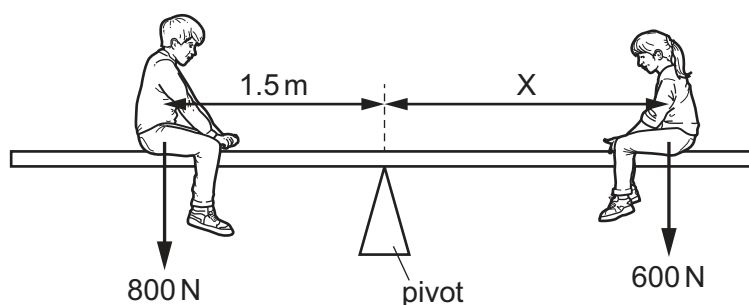

Alan has a weight of 800N and Sarah has a weight of 600N.

What is distance X?

- A 0.5 m B 0.75 m C 1.1 m D 2.0 m
- 32 An electric motor lifts a weight of 8 N through a height of 5 m in 4 s.
- What is the useful power developed?
- A 2.5 W B 6.4 W C 10 W D 40 W

- 33 An iron plate has a circular hole cut out of it as shown.

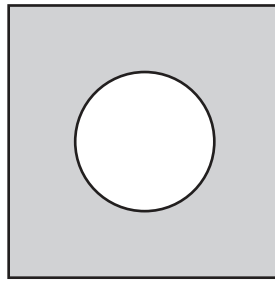

The plate temperature is raised from 20°C to 40°C .

What change is observed?

- A The diameter of the hole increases.
 - B The length of the side of the plate stays the same.
 - C The radius of the hole decreases.
 - D The thickness of the plate decreases.
- 34 A semi-circular block is made from plastic. A ray of light passes through it at the angles shown.

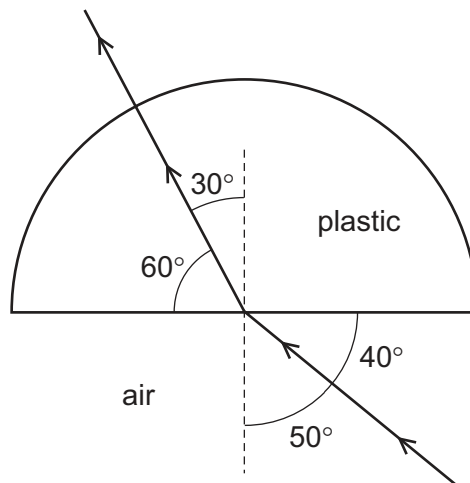

What is the refractive index of the plastic?

- A 0.74
 - B 1.29
 - C 1.53
 - D 1.67
- 35 Which component of the electromagnetic spectrum has the longest wavelengths?
- A gamma rays
 - B radio waves
 - C visible light
 - D X-rays

36 Two resistors are connected in a circuit as shown.

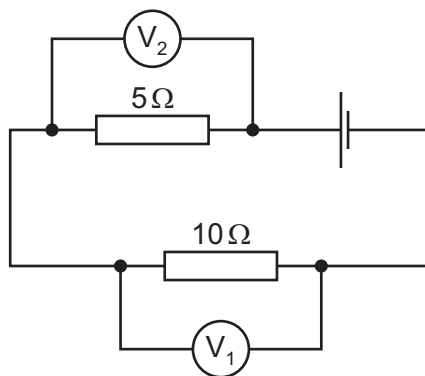

The reading on the voltmeter V_1 is 2 V.

Which statement is correct?

- A The current in the $5\ \Omega$ resistor is greater than the current in the $10\ \Omega$ resistor.
- B The current in the $10\ \Omega$ resistor is 20 A.
- C The electromotive force of the cell is 3 V.
- D The reading of the voltmeter V_2 is 4 V.

37 In the circuit shown the reading on the ammeter is 1 A.

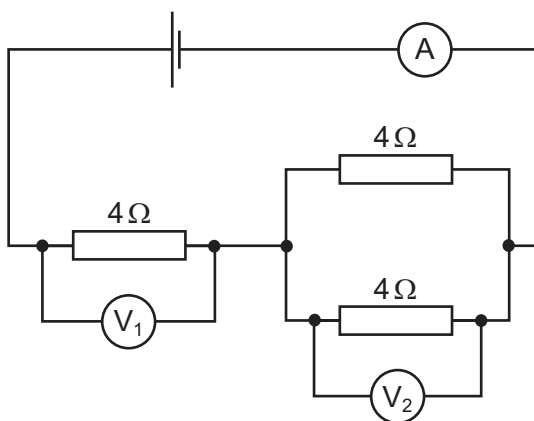

What would be the readings shown by the voltmeters V_1 and V_2 ?

	V_1/V	V_2/V
A	2	2
B	2	4
C	4	4
D	4	2

38 In a household electrical circuit, why are fuses and switches always placed in the live lead?

- A A break in the live wire cuts off the appliance from the voltage supply.
- B A break in the neutral wire would not stop current in the circuit.
- C The live wire carries a greater current.
- D The neutral wire carries no current.

39 The diagrams show the same magnet being moved into or out of different coils.

In which diagram is the magnitude of the induced electromotive force (e.m.f.) the greatest?

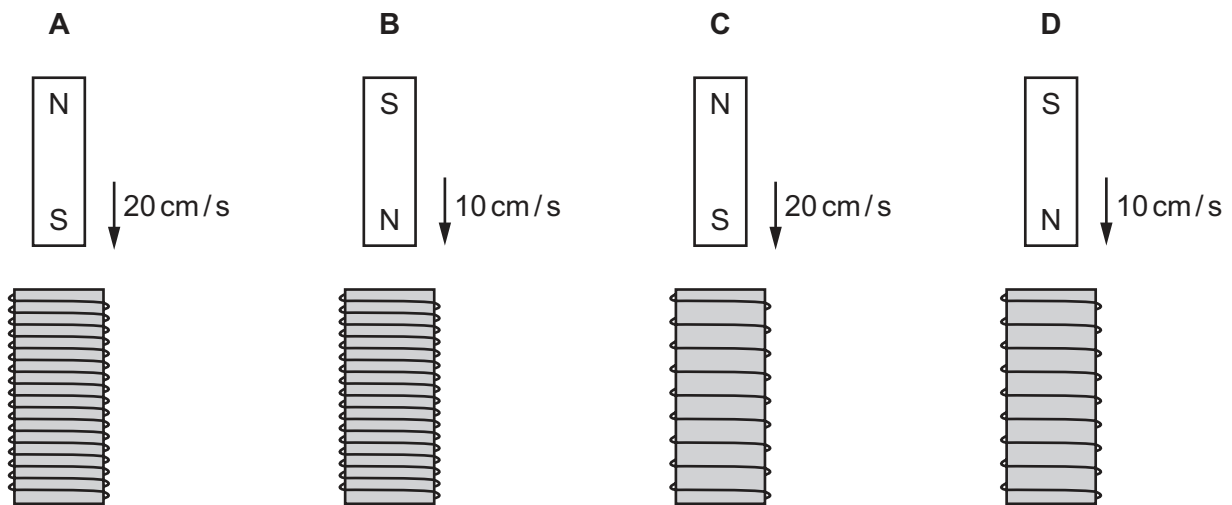

40 After use, a radioactive source still contains material that is radioactive.

How may it be disposed of safely?

- A by burning the source at high temperatures
- B by burying the source deep underground
- C by cooling the source quickly to a very low temperature
- D by washing the source into a fast-flowing river

BLANK PAGE

Permission to reproduce items where third-party owned material protected by copyright is included has been sought and cleared where possible. Every reasonable effort has been made by the publisher (UCLES) to trace copyright holders, but if any items requiring clearance have unwittingly been included, the publisher will be pleased to make amends at the earliest possible opportunity.

To avoid the issue of disclosure of answer-related information to candidates, all copyright acknowledgements are reproduced online in the Cambridge International Examinations Copyright Acknowledgements Booklet. This is produced for each series of examinations and is freely available to download at www.cie.org.uk after the live examination series.

Cambridge International Examinations is part of the Cambridge Assessment Group. Cambridge Assessment is the brand name of University of Cambridge Local Examinations Syndicate (UCLES), which is itself a department of the University of Cambridge.

The Periodic Table of Elements

		Group																				
I	II	III	IV	V	VI	VII	VIII															
3 Li lithium 7	4 Be beryllium 9	11 Na sodium 23	12 Mg magnesium 24	19 K potassium 39	20 Ca calcium 40	21 Sc scandium 45	22 Ti titanium 48	23 V vanadium 51	24 Cr chromium 52	25 Mn manganese 55	26 Fe iron 56	27 Co cobalt 59	28 Ni nickel 59	29 Cu copper 64	30 Zn zinc 65	31 Ga gallium 70	32 Ge germanium 73	33 As arsenic 75	34 Se selenium 79	35 Br bromine 80	36 Kr krypton 84	
37 Rb rubidium 85	38 Sr strontium 88	39 Y yttrium 89	57-71 lanthanoids	72 Hf hafnium 178	73 Ta tantalum 181	74 W tungsten 184	75 Re rhenium 186	76 Os osmium 190	77 Ir iridium 192	78 Pt platinum 195	79 Au gold 197	80 Hg mercury 201	81 Tl thallium 204	82 Pb lead 207	83 Bi bismuth 209	84 Po polonium —	85 At astatine —	86 Rn radon —				
87 Fr francium —	88 Ra radium —	89 Ac actinium —	89-103 actinoids	104 Rf rutherfordium —	105 Db dubnium —	106 Sg seaborgium —	107 Bh bohrium —	108 Hs hassium —	109 Mt meitnerium —	110 Ds darmstadtium —	111 Rg roentgenium —	112 Cn copernicium —	114 Fl flerovium —	116 Lv livermorium —								

Key
atomic number
atomic symbol
name
relative atomic mass

1
H
hydrogen
1

57 La lanthanum 139	58 Ce cerium 140	59 Pr praseodymium 141	60 Nd neodymium 144	61 Pm promethium —	62 Sm samarium 150	63 Eu europium 152	64 Gd gadolinium 157	65 Tb terbium 159	66 Dy dysprosium 163	67 Ho holmium 165	68 Er erbium 167	69 Tm thulium 169	70 Yb ytterbium 173	71 Lu lutetium 175
89 Ac actinium —	90 Th thorium 232	91 Pa protactinium 231	92 U uranium 238	93 Np neptunium —	94 Pu plutonium —	95 Am americium —	96 Cm curium —	97 Bk berkelium —	98 Cf californium —	99 Es einsteinium —	100 Fm fermium —	101 Md mendelevium —	102 No nobelium —	103 Lr lawrencium —

lanthanoids

actinoids

The volume of one mole of any gas is 24 dm³ at room temperature and pressure (r.t.p.).